



# *Guide for sorting plastic parts DAF XF series*

*Give plastics a second life*



# Optimum concern for the environment

**PP**

*Polypropylene*

**ABS/ASA**

*Acrylonitrile Butadiene Styrene /  
Acrylonitrile Styrene Acrylate*

**UPGF**

*Glass-fibre reinforced Polyester*

**PMMA**

*Polymethyl Methacrylate*

**Other**

**PUR**

*Polyurethane*

**PVC**

*Polyvinyl Chloride*

**PE**

*Polyethylene*

**PA**

*Polyamide*

DAF Trucks operates an active environmental policy. The company has been a frontrunner in the development of quieter trucks and cleaner engines for many years, and has given considerable priority to environmentally- friendly production processes. In painting installations at DAF Trucks mainly water-based paint systems are used, and both production and office waste is collected and separated for appropriate disposal. Moreover, environmentally-conscious product development means that the environmental aspects of each new product are taken into account, at the start of the design process. Environmental protection systems are as important to DAF as our quality assurance systems.

**It should therefore be no surprise to learn that DAF Trucks was one of the first companies in the truck industry to achieve ISO 14001-certification for its environmental management system.**

## **Recycling**

Recycling – in other words the re-use of materials - also represents a key component of DAF Trucks' environmental policy. This approach saves raw material and reduces the size of the refuse mountain. Clearly, trucks are mainly built out of metal parts and metal, by its very nature, is easy to recycle. However, more and more plastics are being introduced into the commercial vehicle industry. The majority of plastics can also be easily recycled, so long as a clear identification

of the material type is provided. All plastic parts used in the production plant are therefore issued with a separate material code, to identify the exact plastic type. On the basis of this material code, service engineers will be able to sort and segregate plastic waste, ensuring suitability for reprocessing.

For ease of sorting, DAF Trucks has prepared an inventory of plastic parts introduced in its vehicles and has listed them in Guides for Sorting Plastic Parts. In order to assist in the identification of all parts, each plastic type in these guides has been issued its own unique colour code. As a result, it is no longer necessary to check each individual part for material codes.

*In this way, DAF Trucks is working continuously towards a better environment.*

# Exterieur

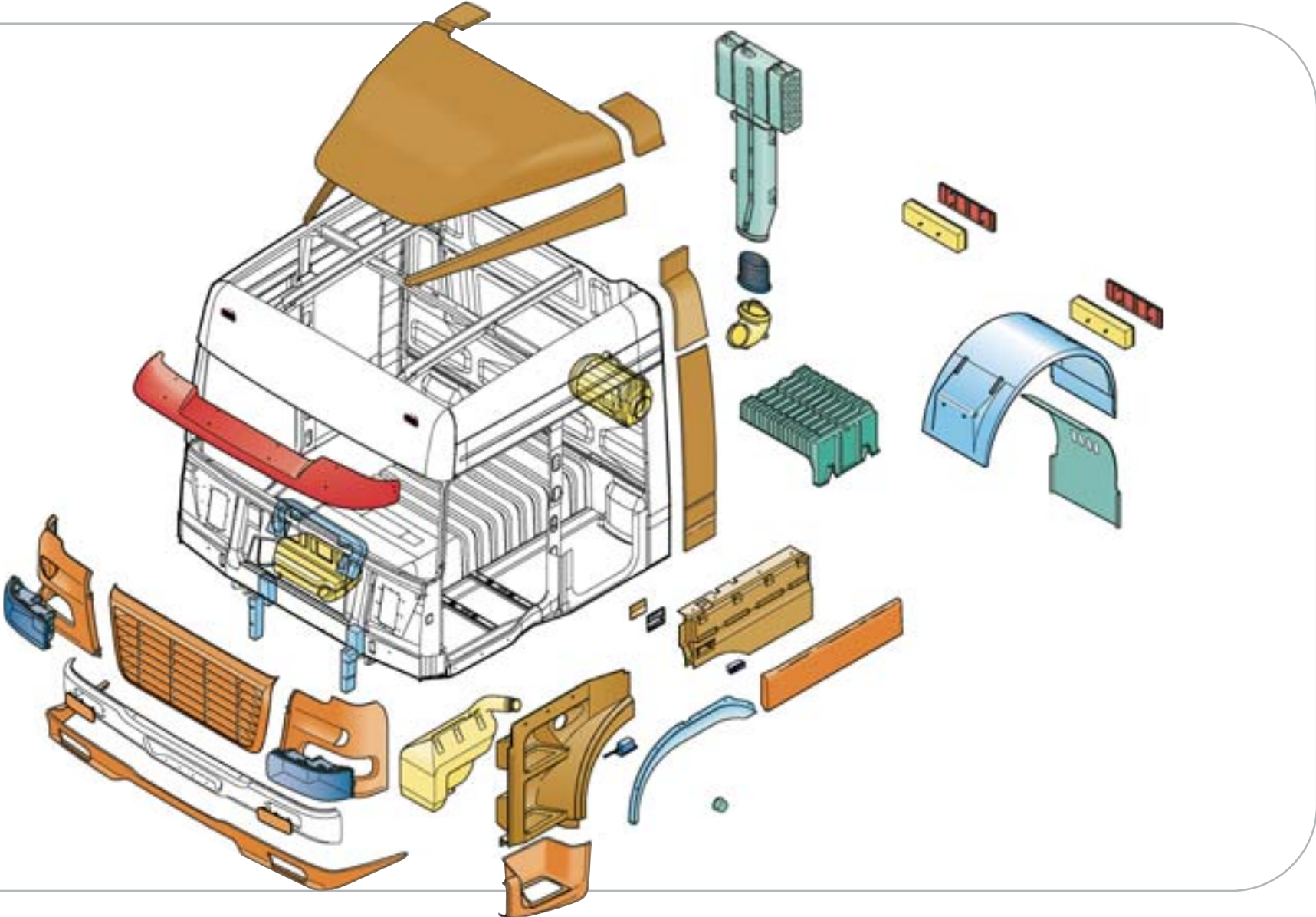

PP

ABS/ASA

UPGF

PMMA

Other

PUR

PVC

PE

PA

PP

ABS/ASA

UPGF

PMMA

Other

PUR

PVC

PE

PA

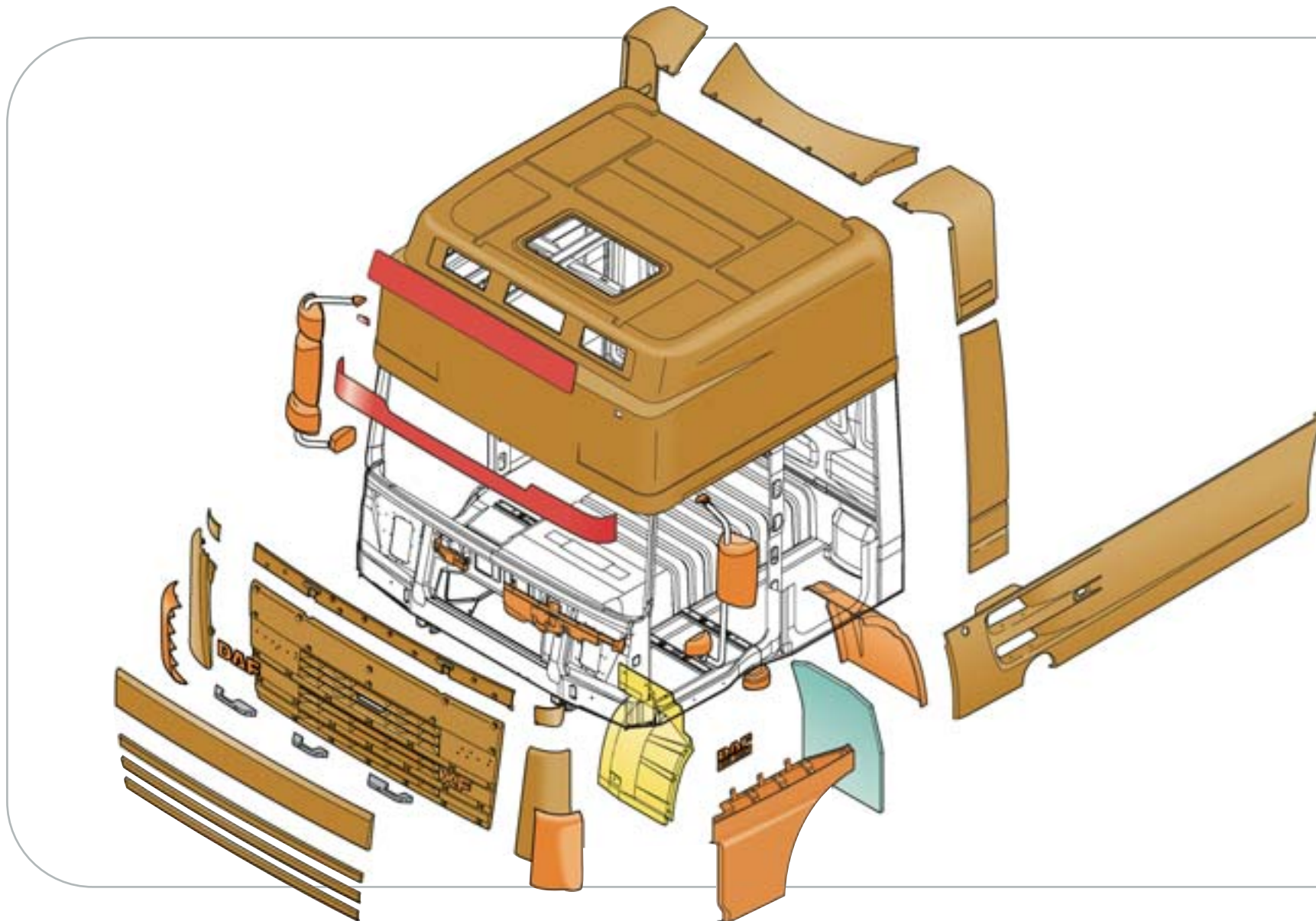

*Dashboard driver side*

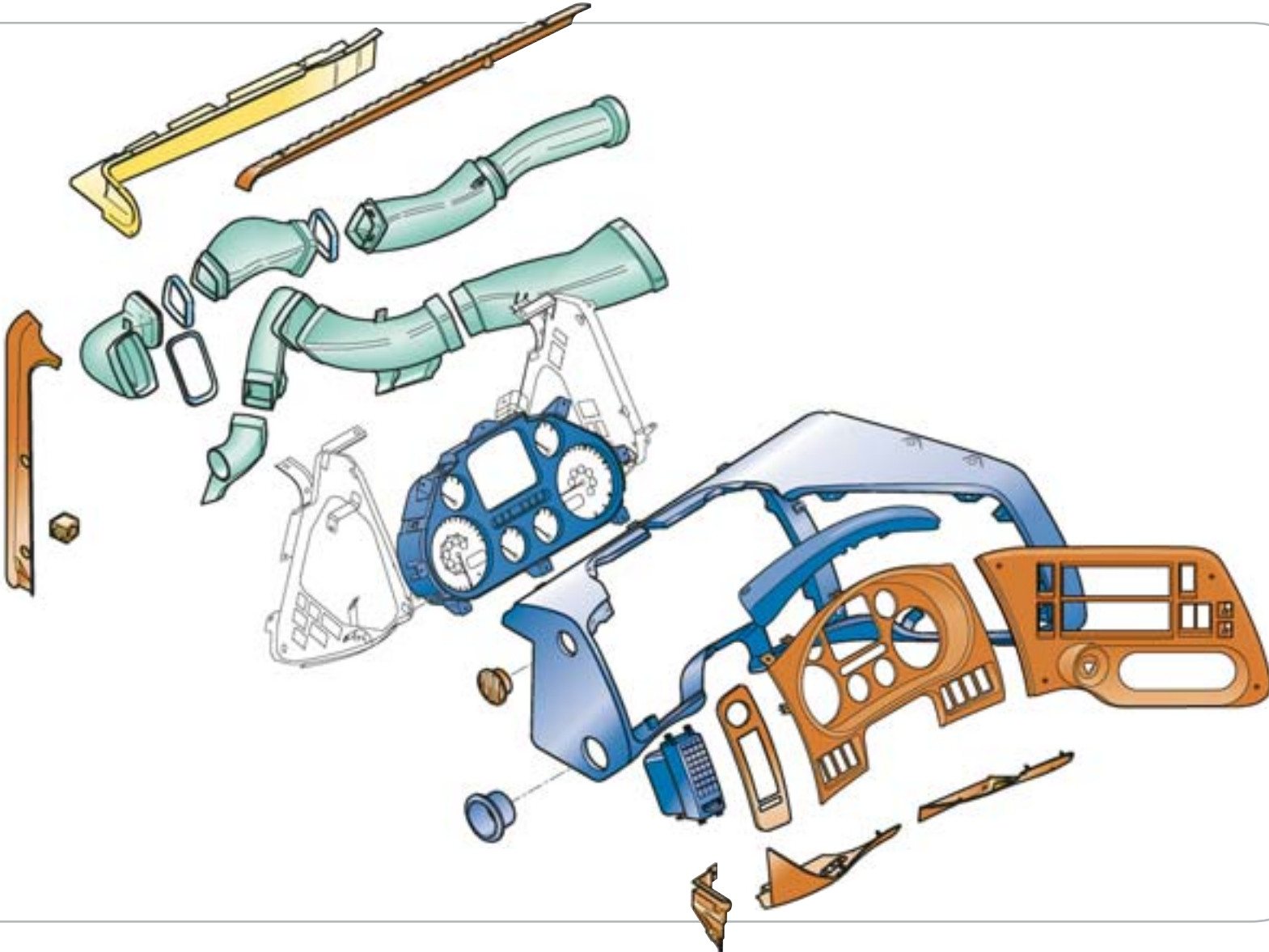

**PP**

**ABS/ASA**

**UPGF**

**PMMA**

**Other**

**PUR**

**PVC**

**PE**

**PA**





## Dashboard co-driver side

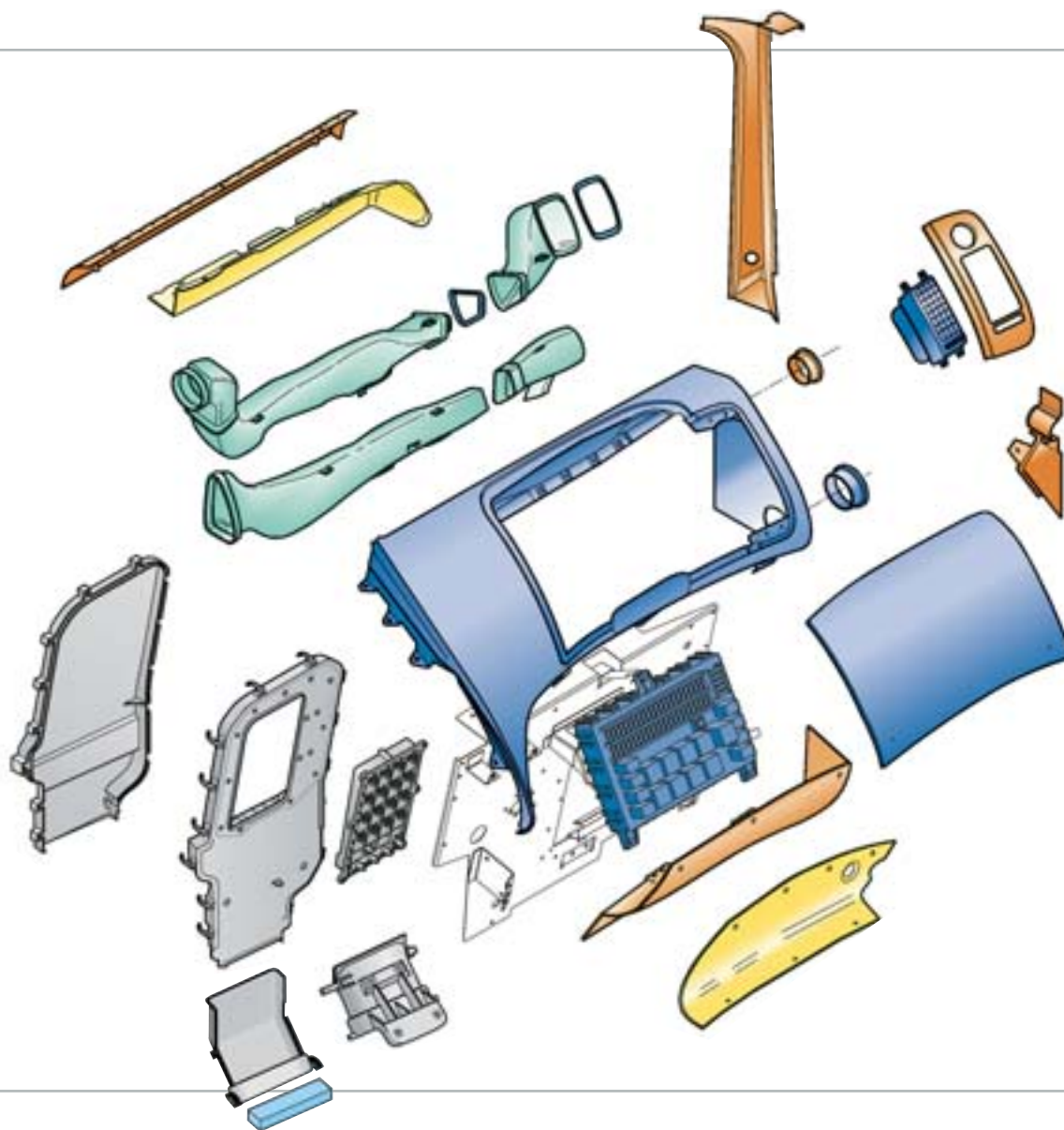

PP

ABS/ASA

UPGF

PMMA

Other

PUR

PVC

PE

PA

## Interior Space Cab

PP

ABS/ASA

UPGF

PMMA

Other

PUR

PVC

PE

PA

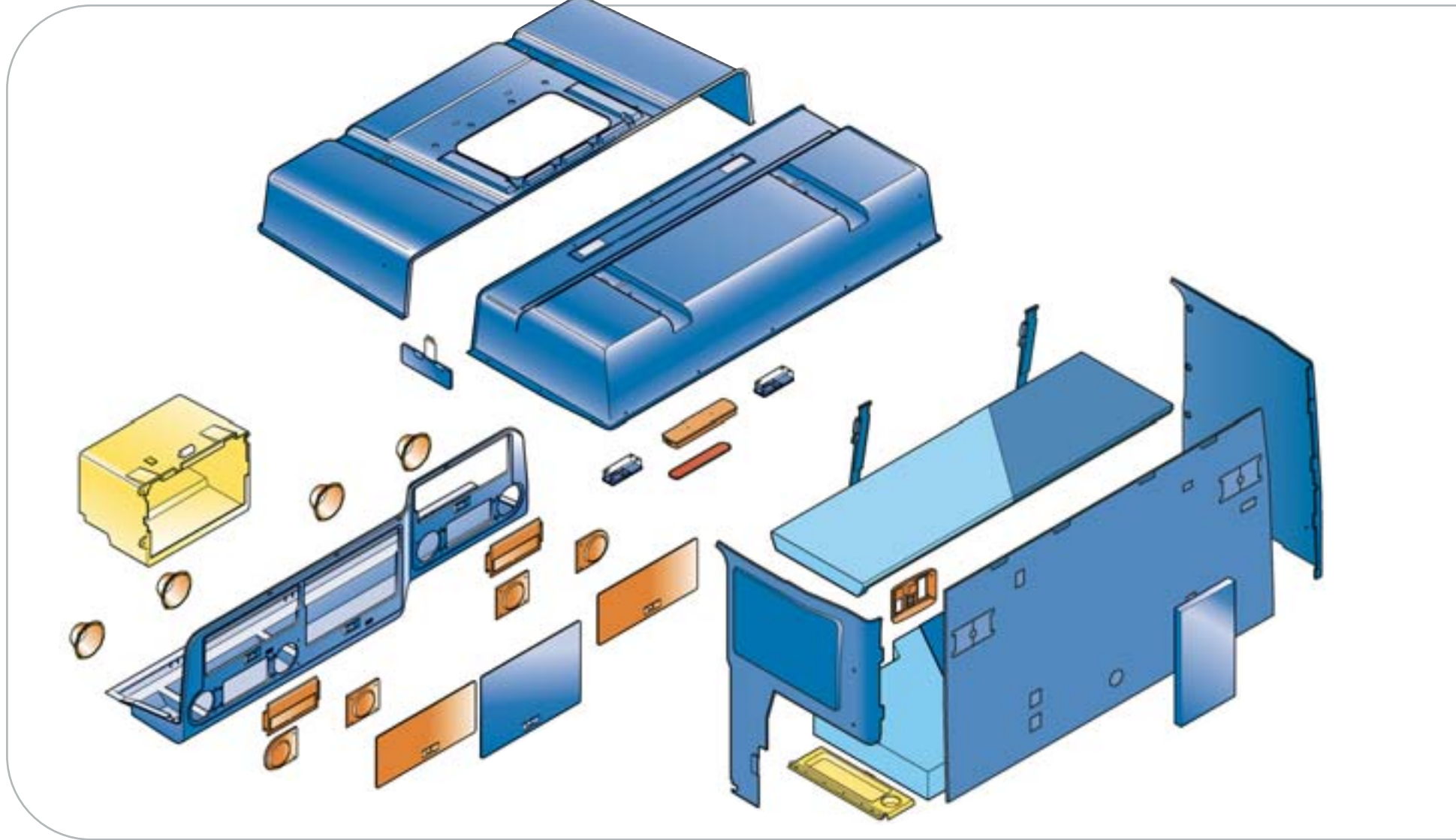



## Interior Super Space Cab

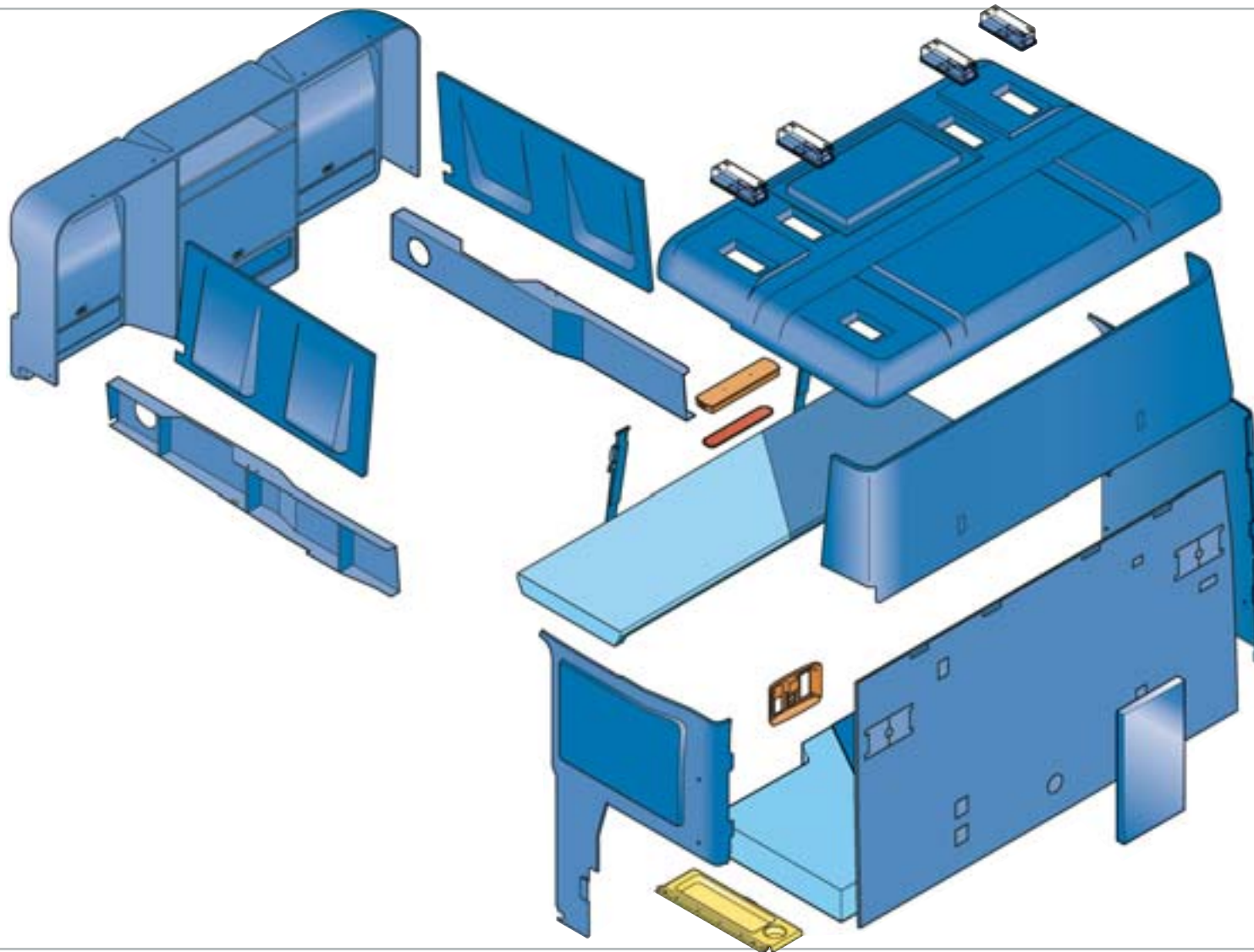

PP

ABS/ASA

UPGF

PMMA

Other

PUR

PVC

PE

PA

## Interior, roof hatch, brake lines

PP

ABS/ASA

UPGF

PMMA

Other

PUR

PVC

PE

PA

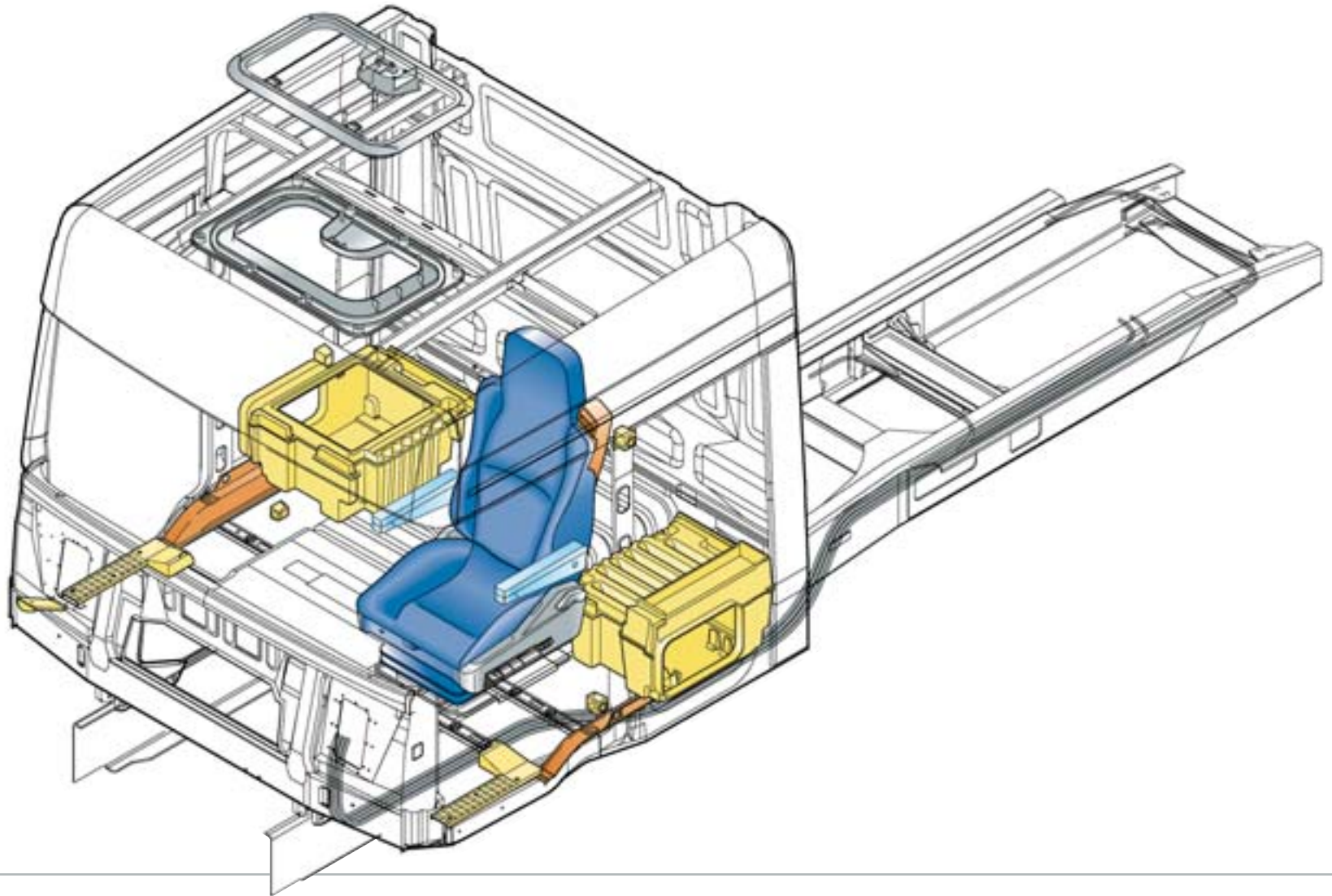

## Mats, door panel, engine encapsulation

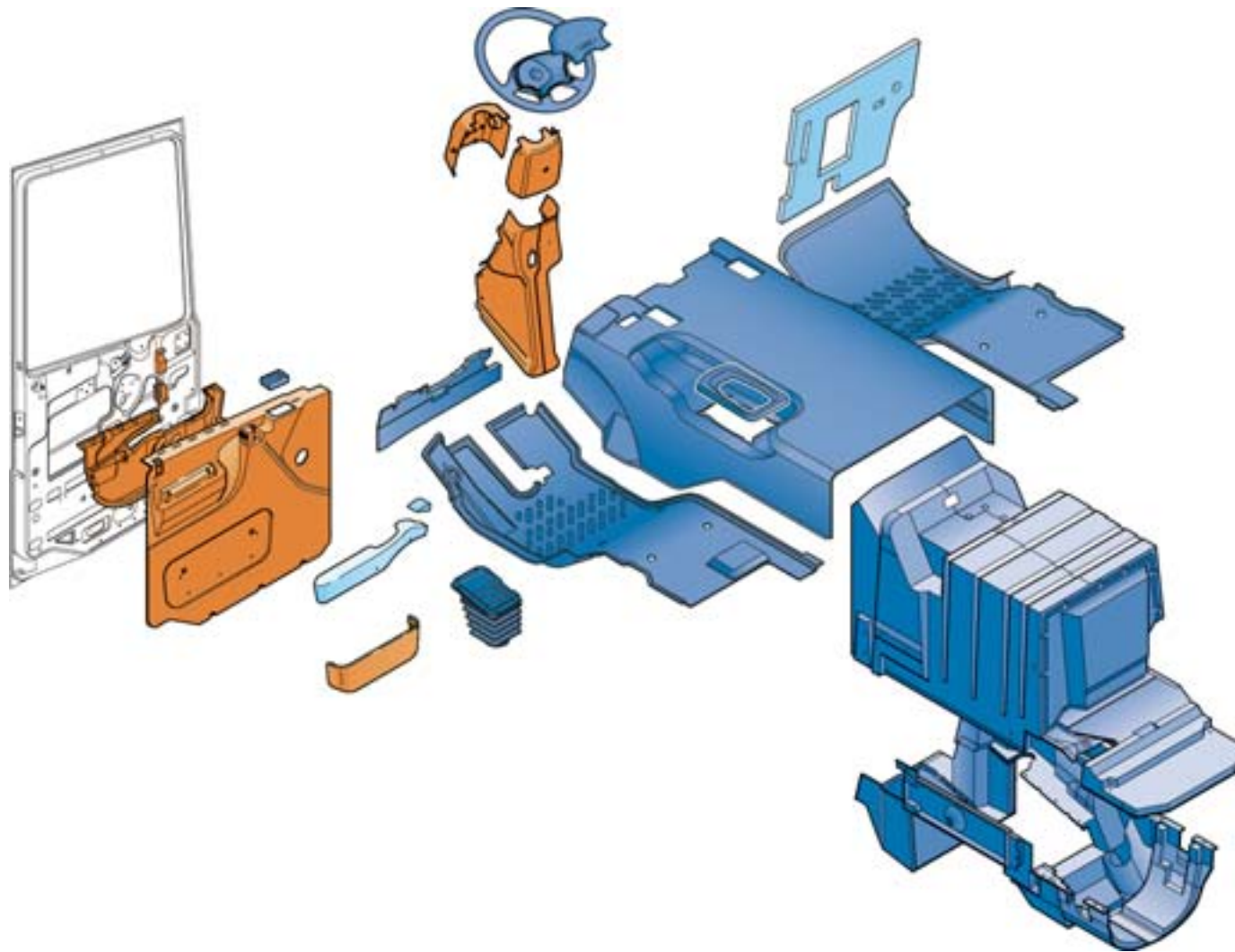

PP

ABS/ASA

UPGF

PMMA

Other

PUR

PVC

PE

PA

In the interest of continuing product development, DAF Trucks reserves the right to change specifications or equipment at any time, without prior notice.

For exact and recent information, please contact your local DAF dealer.

DAF Trucks N.V.  
Hugo van der Goeslaan 1  
P.O. Box 90065  
5600 PT Eindhoven  
The Netherlands  
Tel: +31 (0) 40 21 49 111  
Fax: +31 (0) 40 21 44 325  
[www.daf.com](http://www.daf.com)

*drive your business*

**DAF**

A **PACCAR** COMPANY